



**YANMAR**

AIR-COOLED DIESEL ENGINES

# ***L-N / L-V / L-W Series***

3.5 kW [4.7 HP] – 6.8 kW [9.3 HP]



# AIR-COOLED DIESEL ENGINE

Since 1959, YANMAR has been producing a wide range of compact air-cooled diesel engines ranging in size from 2.6 to 14.7 kW, with total production reaching more than 1.5 million units. Today, these air-cooled diesel engines are powering leading-edge mobile and stationary off-highway equipment around the world.



## L-N Series

**L48N** 3.5kW

**L70N** 4.9kW

**L100N** 7.4kW

### MAIN MARKETS

- Southeast Asia
- Middle East
- Africa

## History

1959 —————> 1966      1966 —————> 1971      1989 —————> 2010

### A / 2A Series 2.6 - 13.2kW 8 models



Main model : A3  
Combustion system : Special swirl chamber type  
Displacement : 0.239L  
No. of Cylinders - Bore x Stroke : 1 -  $\Phi$ 65mm x 72mm  
Rated Output : 3.3kW / 3000min<sup>-1</sup>  
Engine Weight : 49kg

### L / 2L Series 2.6 - 14.7kW 8 models



Main model : L65  
Combustion system : Pre-combustion chamber type  
Displacement : 0.238L  
No. of Cylinders - Bore x Stroke : 1 -  $\Phi$ 65mm x 72mm  
Rated Output : 3.3kW / 3000min<sup>-1</sup>  
Engine Weight : 46kg

### L-A / L-EE Series 2.6 - 7.4kW 12 models



Main model : L60A  
Combustion system : Direct injection type  
Displacement : 0.273L  
No. of Cylinders - Bore x Stroke : 1 -  $\Phi$ 75mm x 62mm  
Rated Output : 4.4kW / 3600min<sup>-1</sup>  
Engine Weight : 39kg



### **L-V Series**

- L48V** 3.4kW
- L70V** 4.8kW
- L100V** 6.8kW

MAIN MARKETS

- E.U.
- Japan



### **L-W Series**

- L70W** 4.8kW
- L100W** 6.8kW

MAIN MARKET

- U.S.A.

# Exceeding Power and Environmental Expectations.

Designed with YANMAR's proprietary direct injection technology, maximum combustion efficiency is achieved through an ideal match between the combustion chamber and injection system. This means a powerful, yet environmentally friendly engine.



## **Compact, Direct Injection Engine = Easy Installation & Low Fuel Consumption**

Keeping with the traditional compact design, the L series engines are simple to install by fitting into cramped spaces without sacrificing power and performance. YANMAR's proprietary direct injection technology allows the engine to sip rather than gorge on fuel, which means lower running costs in the world of rising fuel prices.

## **Quick, Easy Starting With Standard Recoil**

A special auto-return decompressor and YANMAR's own efficient combustion system breeze through starting with electric starting also offered as an option.

## **Low Vibration and Noise**

Superior vibration and noise reduction is achieved through the use of precision balancers, which leads to operating comfort even during long work hours.

## **The Total FIE Expertise Only a Complete Diesel Engine Manufacturer Can Provide**

YANMAR developed one of the world's smallest fuel injection systems. We have since raised it to a level of efficiency that ensures maximum power from every drop of diesel. Its extraordinarily low fuel consumption is a result of our super-precise FIE, and our direct injection system, the first to ever go into this type of engine.



# AIR-COOLED DIESEL ENGINE

# L-N Series

For regions not subject to emissions regulations

Notes :

- As of 2019
- For information about applications and each country's regulations, please contact your local YANMAR sales network.

## L48N

Rated Output (Gross)

**3.5kW**  
/3600min<sup>-1</sup>



PERFORMANCE CURVES L48N5

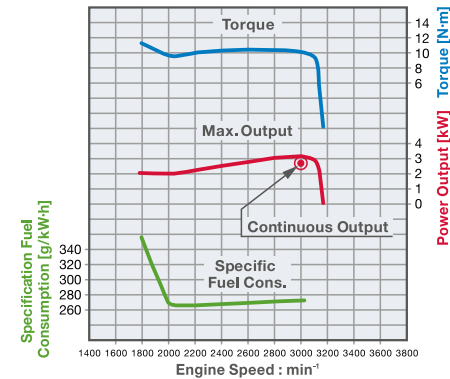

PERFORMANCE CURVES L48N6

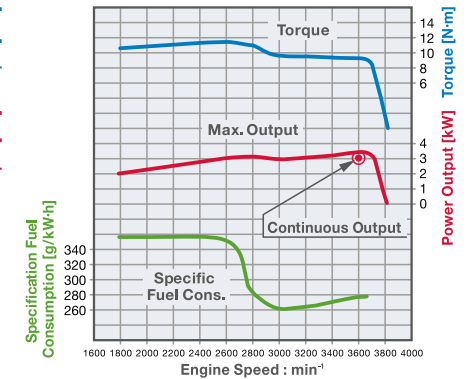

\* Note: Performance based on the following conditions.

### DIMENSIONS [ mm ]

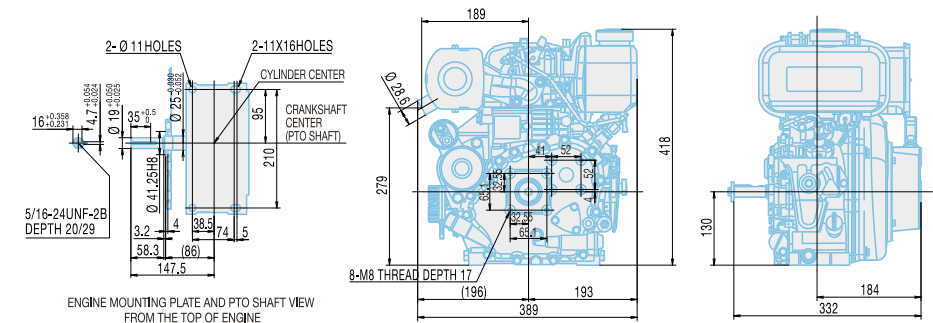

# L70N

Rated Output (Gross)

## 4.9kW

/3600min<sup>-1</sup>



# L100N

Rated Output (Gross)

## 7.4kW

/3600min<sup>-1</sup>



PERFORMANCE CURVES L70N5

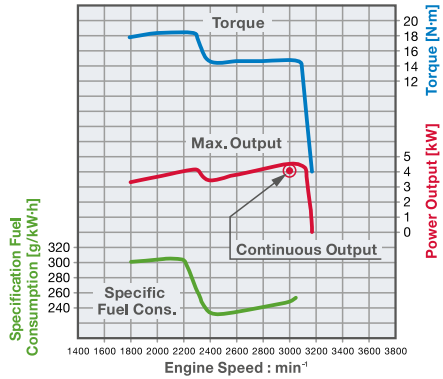

PERFORMANCE CURVES L70N6

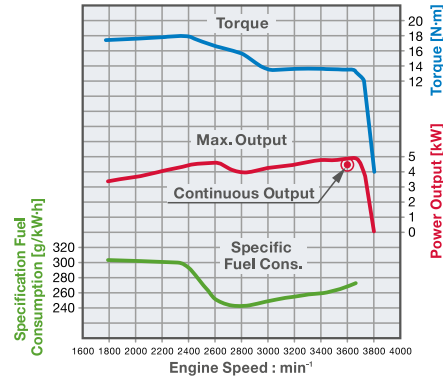

\* Note: Performance based on the following conditions.

PERFORMANCE CURVES L100N5

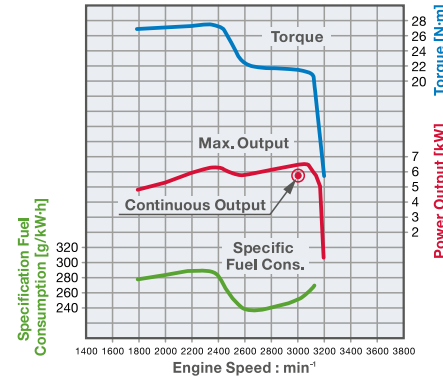

PERFORMANCE CURVES L100N6

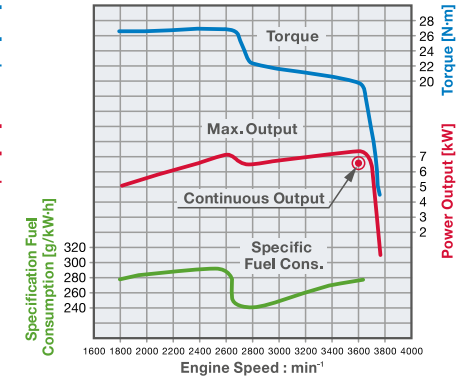

\* Note: Performance based on the following conditions.

## DIMENSIONS [ mm ]

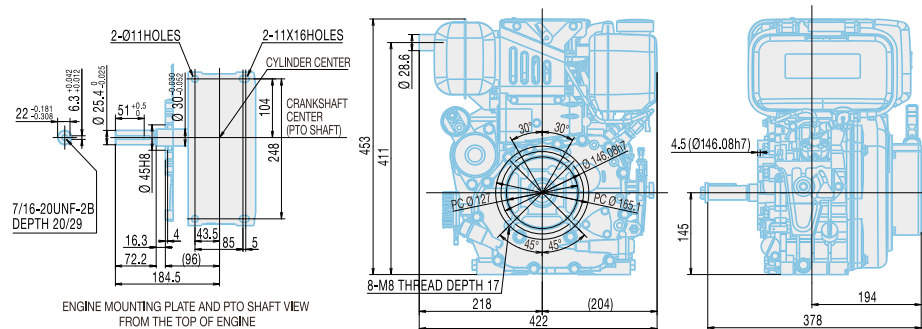

## DIMENSIONS [ mm ]

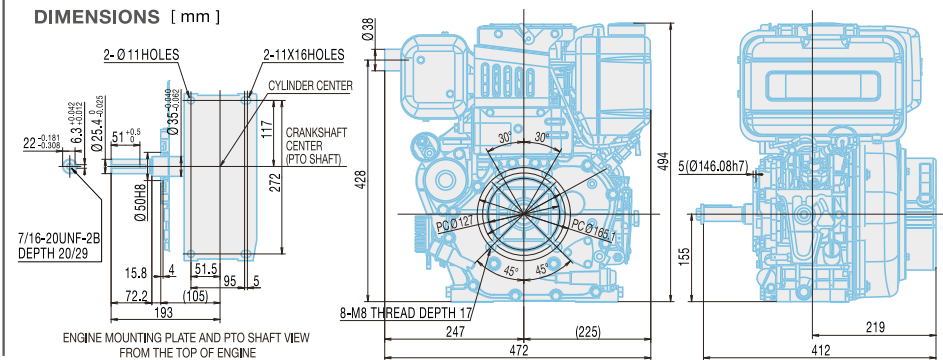

\* • After 30 hrs. initial running • Atmospheric conditions: Temperature 298K(25° C) / Pressure 100kPa (750mmHg) / Humidity 30%

# AIR-COOLED DIESEL ENGINE

# L-V Series

## EU Stage V

Notes :

- As of 2019
- For information about applications and each country's regulations, please contact your local YANMAR sales network.

## An ideal match between the combustion system and the injection system

Boasting many features superior to the conventional L series, L-V series engines also achieve lower levels of emissions through technology. High-pressure injection technology minimizes the fuel required for ignition, while the combustion chamber itself is also improved, and there is an EGR(Exhaust Gas Recirculation) system for recirculating some of the exhaust gas back into the air intake. Only L48V reduces exhaust emission using a DOC(Diesel Oxydation Catalyst).



# L48V

Rated Output (Gross)

# 3.4kW

/3600min<sup>-1</sup>



PERFORMANCE CURVES L48V5

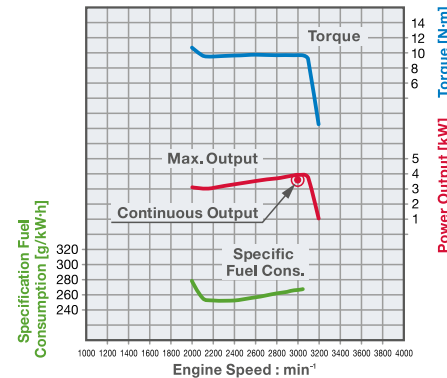

PERFORMANCE CURVES L48V6

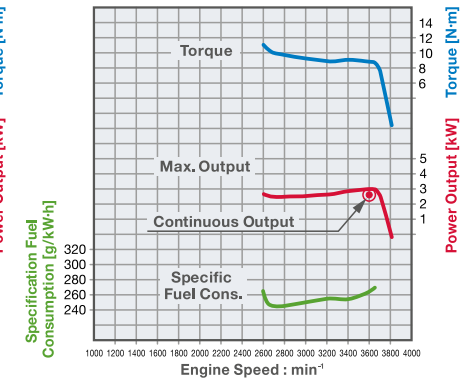

\* Note: Performance based on the following conditions.

## DIMENSIONS [ mm ]

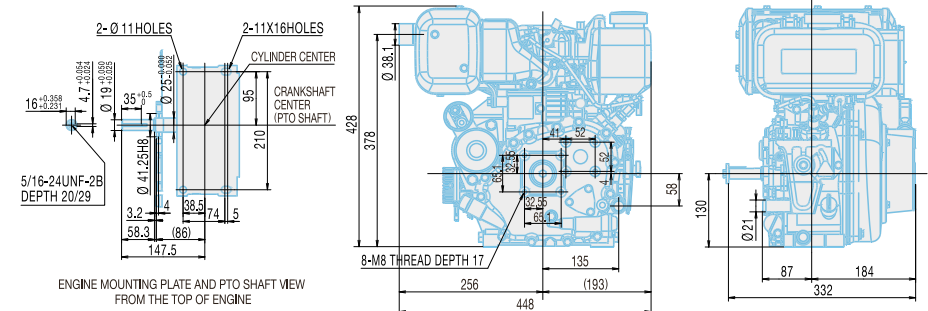



# L70V

Rated Output (Gross)

## 4.8kW

/3600min<sup>-1</sup>



# L100V

Rated Output (Gross)

## 6.8kW

/3600min<sup>-1</sup>



PERFORMANCE CURVES L70V5

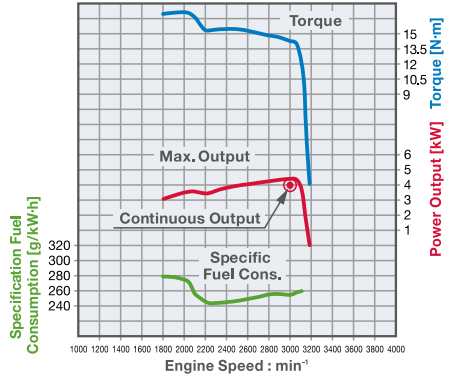

PERFORMANCE CURVES L70V6

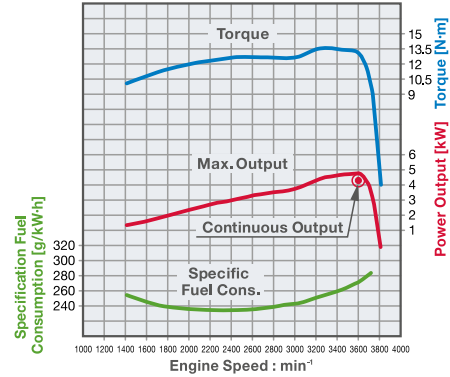

\* Note: Performance based on the following conditions.

PERFORMANCE CURVES L100V5

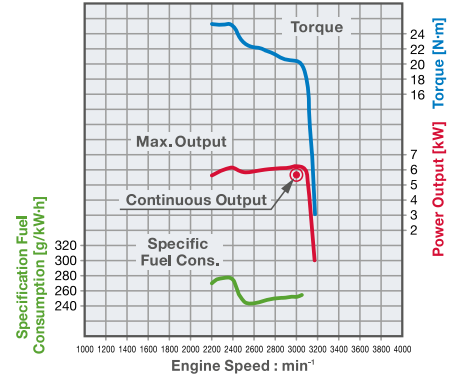

PERFORMANCE CURVES L100V6

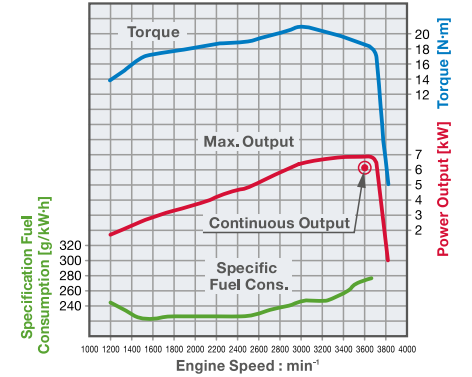

\* Note: Performance based on the following conditions.

## DIMENSIONS [ mm ]

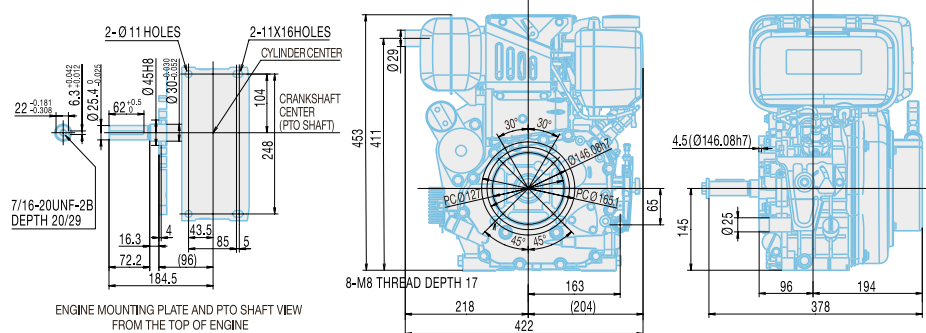

## DIMENSIONS [ mm ]

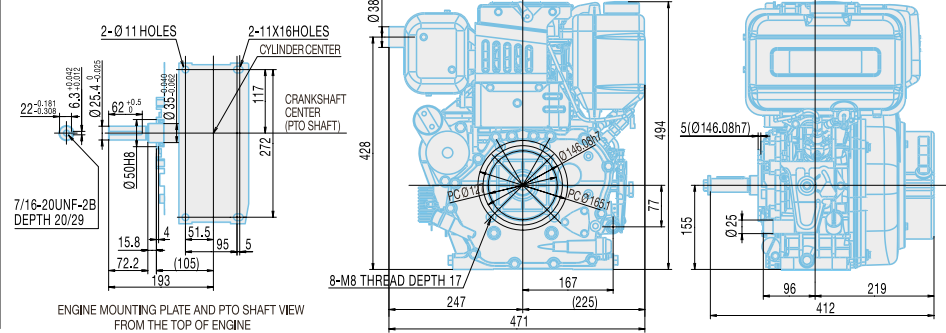

\* • After 30 hrs. initial running • Atmospheric conditions: Temperature 298K(25° C) / Pressure 100kPa (750mmHg) / Humidity 30%

# AIR-COOLED DIESEL ENGINE

# L-W

# Series

## EPA Final Tier 4

Notes :

- As of 2019
- For information about applications and each country's regulations, please contact your local YANMAR sales network.

# L70W



Rated Output (Gross)

# 4.8kW

/3600min<sup>-1</sup>

PERFORMANCE CURVES L70W6

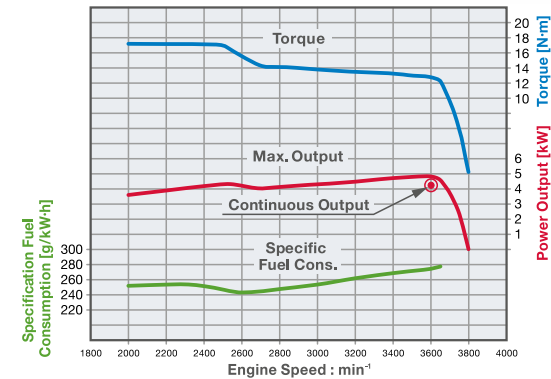

\* Note: Performance based on the following conditions.

## DIMENSIONS [ mm ]

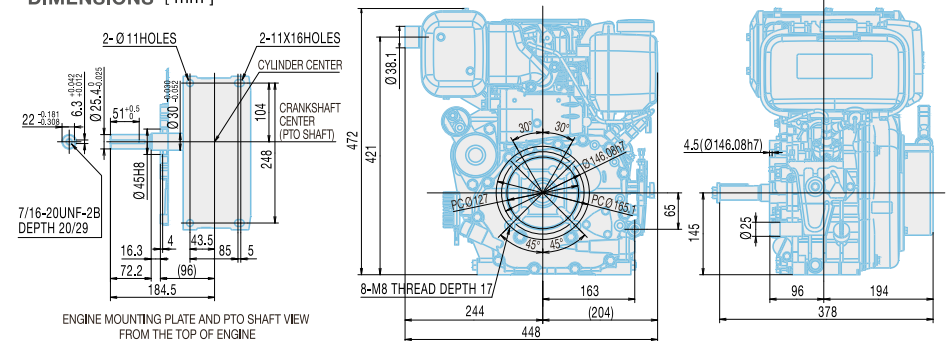

# L100W



Rated Output (Gross)

## 6.8kW

/3600min<sup>-1</sup>

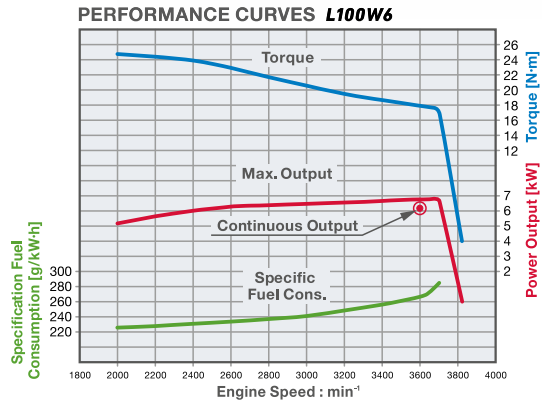

\* Note: Performance based on the following conditions.

### DIMENSIONS [ mm ]

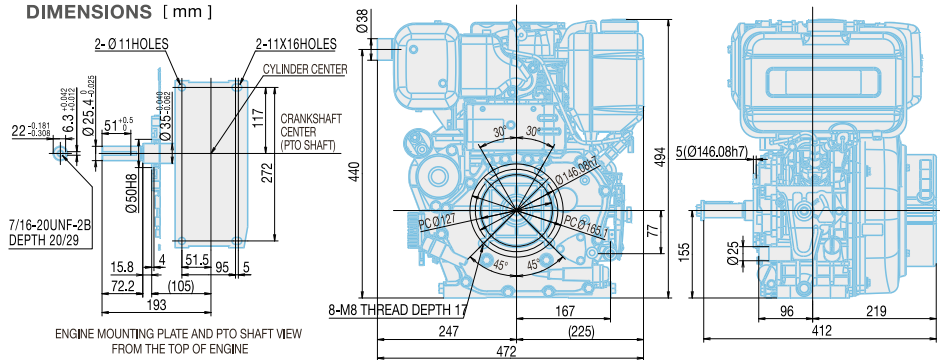

\* • After 30 hrs. initial running • Atmospheric conditions: Temperature 298K(25°C) / Pressure 100kPa(750mmHg) / Humidity 30%

## Powerful and clean engines for a new generation

Taking over the combustion system of L-V series engines, the L-W series engines reduce exhaust emissions using a Diesel Oxidation Catalyst.

YANMAR continues to improve our technology, and contribute to the future of the Earth.

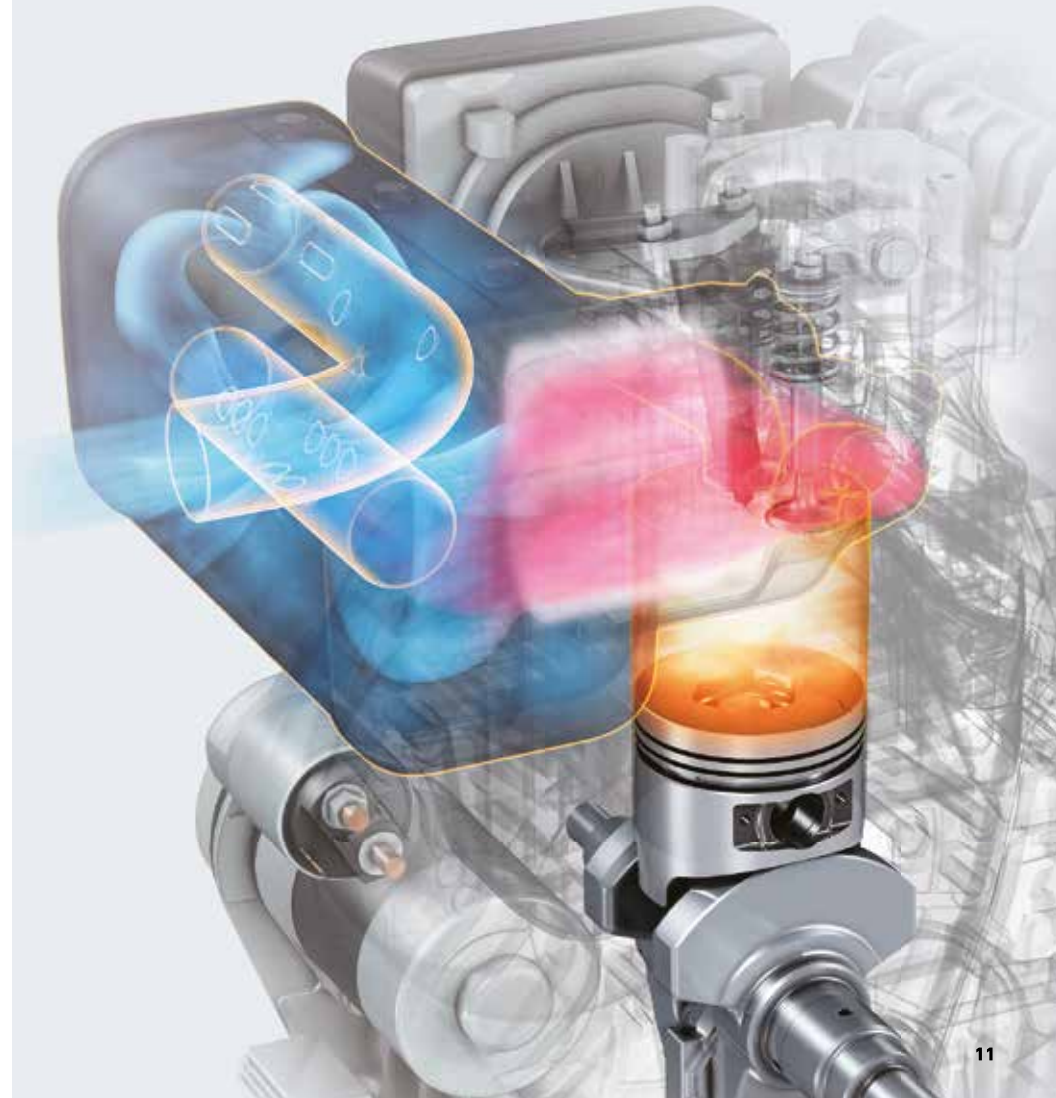

# Engine Specifications

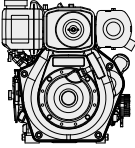
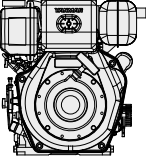
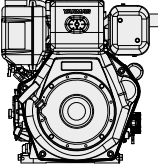
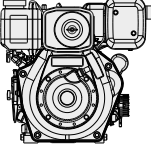
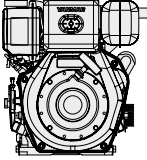
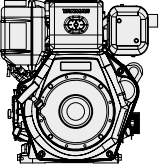
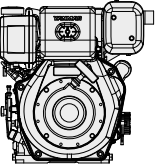
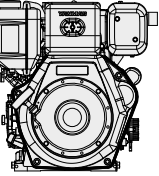
Engine Series		L-N Series						L-V Series						L-W Series					
Engine Model		L48N		L70N		L100N		L48V		L70V		L100V		L70W		L100W			
																			
Type		4 stroke, vertical cylinder, air-cooled diesel engine																	
ATS(After Treatment System)		-						DOC		-									
No. of Cylinders		1																	
Bore x Stroke		mm		Φ70 × 57		Φ78 × 67		Φ86 × 75		Φ70 × 57		Φ78 × 67		Φ86 × 75		Φ78 × 67		Φ86 × 75	
Displacement		liter		0.219		0.320		0.435		0.219		0.320		0.435		0.320		0.435	
Continuous Rated Output	Engine Speed	rpm(min <sup>-1</sup> )		3600	3000	3600	3000	3600	3000	3600	3000	3600	3000	3600	3000	3600	3000	3600	3000
	Output	kW		3.1	2.8	4.4	4.1	6.6	5.7	3.1	2.7	4.3	4.0	6.2	5.7	4.3	3.9	6.2	5.7
Maximum Rated Output	Engine Speed	rpm(min <sup>-1</sup> )		3600	3000	3600	3000	3600	3000	3600	3000	3600	3000	3600	3000	3600	3000	3600	3000
	Output / Eng. Speed	kW		3.5	3.1	4.9	4.5	7.4	6.5	3.4	3.0	4.8	4.4	6.8	6.3	4.8	4.3	6.8	6.3
High Idling		rpm(min <sup>-1</sup> )		3800±30	3175±30	3800±30	3175±30	3800±30	3175±30	3800±30	3175±30	3800±30	3175±30	3800±30	3175±30	3800±30	3175±30	3800±30	3175±30
Engine Weight (Dry)	Electric Starter	kg		32.0		41.0		53.5		34.5		41.0		53.5		43.0		53.5	
	Recoil Start	kg		27.0		36.0		48.5		29.5		36.0		48.5		38.0		48.5	
Cooling System		Forced air-cooling by flywheel fan																	
Lubricating System		Forced lubricating system																	
Starting System		Electric start / Recoil start																	
Dimension	Overall Length (L)	mm		332		378		412		332		378		412		395		429	
	Overall Width (W)	mm		384		422		472		448		422		472		448		472	
	Overall Height (H)	mm		417		453		494		425		453		494		472		494	
Lubricating System	Dispstick Upper Limit	liter		0.8		1.1		1.6		0.8		1.1		1.6		1.1		1.6	
	Dispstick Lower Limit	liter		0.6		0.7		1.0		0.6		0.7		1.0		0.7		1.0	
Fuel Oil Tank Capacity		liter		2.4		3.3		5.4		2.4		3.3		5.4		3.3		5.4	

Note : Specifications are subject to change depending on the engine parts and optional kits selected.

# Accessories

○ = Standard  
△ = Option

Engine Series		L-N Series									L-V Series								L-W Series										
Engine Model		L48N			L70N			L100N			L48V			L70V			L100V				L70W				L100W				
Category *		G	GE	P	G	GE	P	G	GE	P	G	GE	P	G	GE	P	V	G	GE	P	V	G	GE	P	V	G	GE	P	V
Fuel system	Fuel tank (2.4 liter)	○	○	○							○	○	○																
	Fuel tank (3.3 liter)				○	○	○							○	○	○	○					○	○	○	○				
	Fuel tank (5.4 liter)							○	○	○								○	○	○	○					○	○	○	○
	w/o Fuel tank	△	△	△	△	△	△	△	△	△	△	△	△	△	△	△	△	△	△	△	△	△	△	△	△	△	△	△	△
Starting system	Starting motor (w/Recoil starter)	○	○	○	○	○	○	○	○	○	○	○	○	○	○	○	○	○	○	○	○	○	○	○	○	○	○	○	○
	Recoil starter	△	△	△	△	△	△	△	△	△	△	△	△	△	△	△	△	△	△	△	△	△	△	△	△	△	△	△	△
	Key switch	○	○	○	○	○	○	○	○	○	○	○	○	○	○	△	○	○	○	△	○	○	○	△	○	○	○	△	○
	w/o Key switch	△	△	△	△	△	△	△	△	△	△	△	△	△	△	○	△	△	△	○	△	△	△	○	△	△	△	○	△
Electric system	Charging dynamo (12V-15A)	○	○	○	○	○	○	○	○	○	○	○	○	○	○	○	○	○	○	○	○	○	○	○	○	○	○	○	○
	Charging dynamo (12V-1A)	△	△	△	△	△	△	△	△	△	△	△	△	△	△	△	△	△	△	△	△	△	△	△	△	△	△	△	△
	w/o Charging dynamo	△	△	△	△	△	△	△	△	△	△	△	△	△	△	△	△	△	△	△	△	△	△	△	△	△	△	△	△
PTO system	Straight (E-D)	○			○			○			○			○			△	○			△	○			△	○			△
	Straight (D)	△			△			△			△			△			○	△			○	△			○	△			○
	Taper (E-DG)		○			○			○			○						○				○				○			
	Taper (DG)		△			△			△			△						△				△				△			
	Taper (E-DI)		△			△			△			△						△				△				△			
	Thread (E-DP)			○			○			○			○						○				○				○		
Thread (DP)			△			△					△											△							
Speed control device	General use (by remote & hand)	○	△	△	○	△	△	○	△	△	○	△	△	○	△	△	△	○	△	△	△	○	△	△	△	○	△	△	△
	Constant speed type (by hand)	△	○	△	△	○	△	△	○	△	△	○	△	△	○	△	△	△	○	△	△	△	○	△	△	△	○	△	△
	Friction plate type (by hand)	△	△	○	△	△	○	△	△	○	△	△	○	△	△	○	△	△	○	△	△	△	○	△	△	△	○	△	△
	Remote control type	△	△	△	△	△	△	△	△	△	△	△	△	△	△	○	△	△	△	○	△	△	△	○	△	△	△	△	○
Maintenance tools	○	○	○	○	○	○	○	○	○	○	○	○	○	○	○	○	○	○	○	○	○	○	○	○	○	○	○	○	○

\* : G = General / GE = Generator / P = Pump / V = V-machine  
Note: For other accessories, please contact your YANMAR sales network.

# PTO Dimensions [ mm ]

Application code	Keyway shaft		Taper shaft
	E-D	D	E-DG
<b>L48N</b> <b>L48V</b>  <h1>48</h1>			
<b>L70N</b> <b>L70V</b> <b>L70W</b>  <h1>70</h1>			
<b>L100N</b> <b>L100V</b> <b>L100W</b>  <h1>100</h1>			

Thread shaft

PTO Flanges

DG

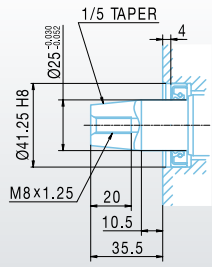

E-DI

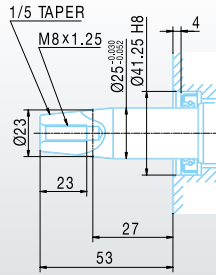

E-DP

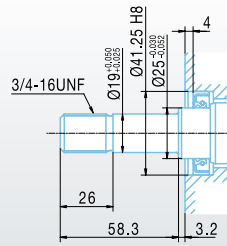

DP

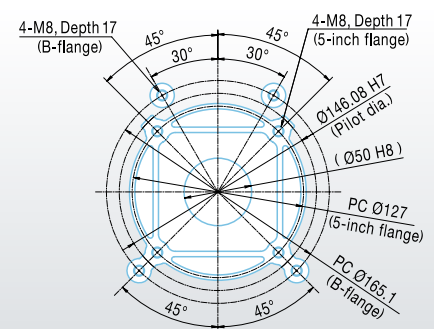
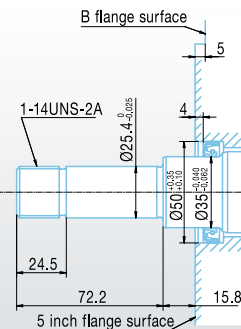
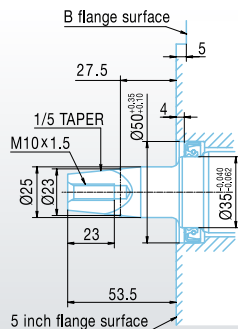
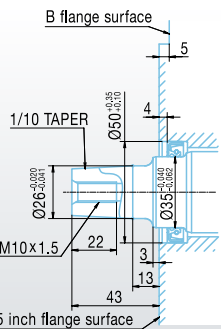
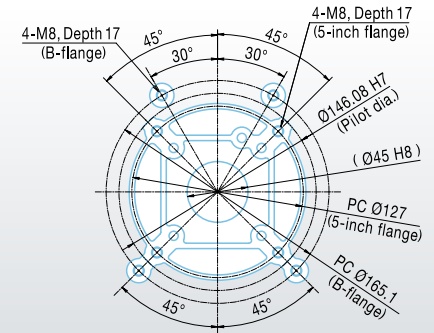
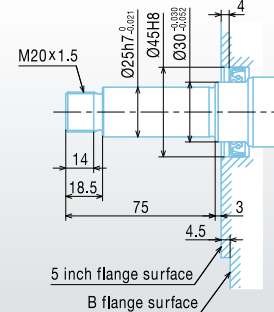
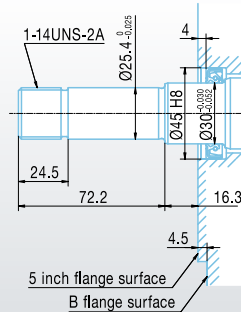
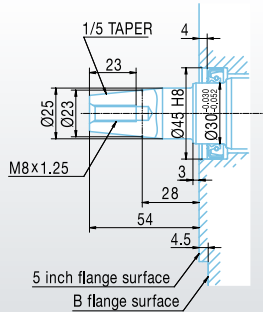
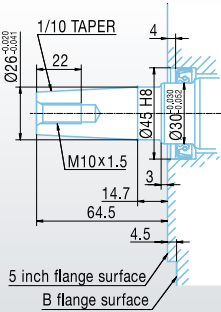
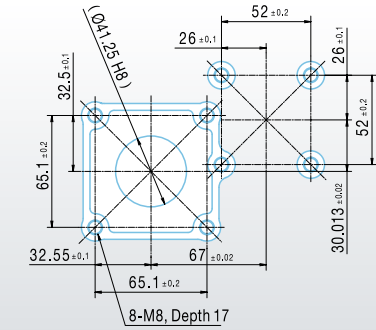
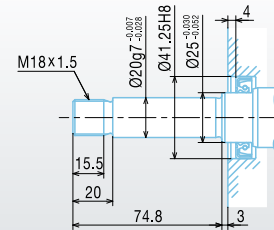



**Head Office**

Yanmar Co., Ltd  
YANMAR FLYING-Y BUILDING  
1-32 Chayamachi, Kita-ku,  
530-8311 Osaka, Japan  
[www.yanmar.com](http://www.yanmar.com)

**Regional Office / Sales & Service**

Yanmar Europe B.V.  
Brugplein 11, 1332 BS Almere, The Netherlands  
T: +31 [0]36 549 3200  
F: +31 [0]36 549 3209  
E: [industrial-yeu@yanmar.com](mailto:industrial-yeu@yanmar.com)  
[www.yanmar.eu](http://www.yanmar.eu)